

附件 • Accessories

VC			50	75	100	150
真空密封灰尘分离器 Dust separator, vacuum tight	ZFP		145 (06)	145 (06)	216 (06)	216 (06)
真空密封进气口过滤器 Vacuum tight suction filter	ZVF		32 (53)	32 (53)	32 (54)	40 (53)
电机启动器 Motor starter	ZMS	50 Hz	100 / 63	100 / 63	100 / 63	160 / 100
		60 Hz	100 / 63	100 / 63	100 / 63	160 / 100

尺寸 • Dimensions [mm]

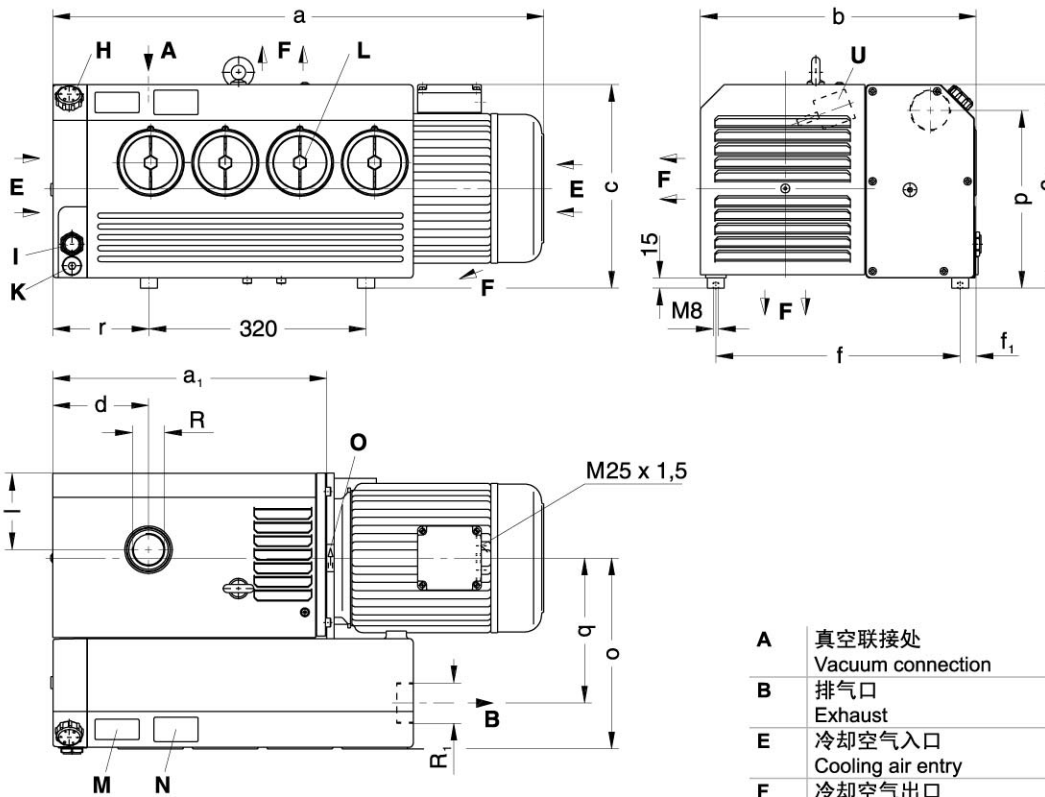

A	真空联接处 Vacuum connection
B	排气口 Exhaust
E	冷却空气入口 Cooling air entry
F	冷却空气出口 Cooling air exit
H	注油口 Oil filling point
I	油位镜 Oil check
K	排油口 Oil drain point
L	油雾分离器 成分VC 50 / 75 -> 3 Oil separator element VC 50 / 75 -> 3 elements
M	油标牌 Oil type plate
N	数据牌 Data plate
O	旋转方向 Direction of rotation
U	气镇阀 Gas ballast valve

VC		50	75	100	150
a	50 Hz	585,5	639,5	707	707
	60 Hz	585,5	639,5	707	724
a₁		316,5	316,5	404	404
b		336	336	406	406
c	50 Hz	-	-	300	300
	60 Hz	-	-	300	315
c₁		267	267	297	297
d		113,5	113,5	141	141
f		287,5	287,5	360	360
f₁		23,5	23,5	24	24
I		90,5	90,5	112	112
o		236	236	281	281
p		242	242	259	259
q		166,5	166,5	214	214
r		104,5	104,5	142	142
R		G 1¼	G 1¼	G 1½	G 1½
R₁		Rp 1¼	Rp 1¼	Rp 2	Rp 2

*与进气口联接的吸气状态有关。工作曲线和数据表是按PNEUROP标准计算的，其所示为真空泵在正常温度下运行。我们保留调整技术数据权利。尺寸a和电流值会因不同电机而与数据表不同。水气容纳，见数据I 200。

* refers to suction conditions at inlet connection. Curves and tables calculated according to PNEUROP standards and refer to vacuum pump at normal operating temperature. The dimensions a and /or drawn the current can differ. Water vapour tolerance, see information I 200.